

SHAFTLESS SCREW CONVEYORS

Shaftless Screw Conveyors



Introduction

The performance and reliability of Sam McCoy's shaftless screw conveyors are proven by the numerous installations for water and wastewater applications as well as palm oil mills across the nation.

Shaftless screw conveyors are widely accepted as an alternative method for the transportation of difficult materials (eg wet pulp, fibrous or sticky substances) due to its efficiency and reliability.

In addition, the fully enclosed system means effective, safe and silent transportation in a clean and odourless environment. The absence of a shaft and intermediate bearings effectively minimize the risk of clogging.

Application

Sam McCoy's shaftless screw conveyors are used in palm oil mills for various stages of transportation including transportation of sterilised loose fruits, nuts, kernels, shells, sludge, fuel and fibre.

Shaftless screw conveyors are also widely used in other applications including transportation of screenings, dewatered sludge, grit and sand.

Sam McCoy's shaftless screw conveyors can easily be custom-designed to suit your application or requirements.

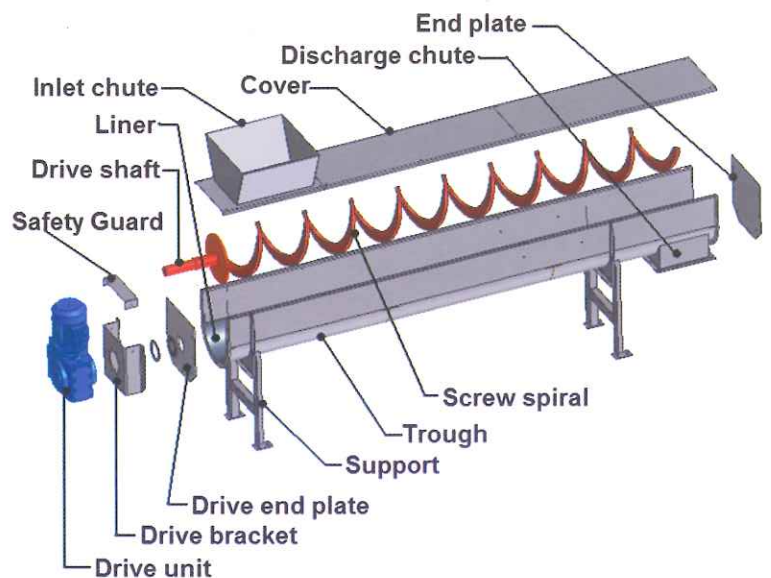

Shaftless Screw Conveyors



Advantages

- No clogging under peak loads
- No fouling from hanger bearings
- No shaft fouling by stringy materials
- No leakage
- Longer lifespan and lower maintenance
- No chains or bearings - very low failure rate
- No carry-over at discharge
- Can handle large lumps
- In-line discharge possible
- Sealed system - spillage and odours are contained
- Higher filling rates
- Smaller footprint

Technical Specifications

Spiral	: High Tensile Steel
Liners	: UHMW Polyethylene Hardox Stainless Steel
Drive unit	: Direct Coupled Variable Speed Option
Troughs	: Fully Enclosed and Bolted AISI 304, AISI 316, Mild Steel
Seals	: Gland Packing
Other options	: Supports Electronic Load Monitoring Automatic Controls Motion Sensors

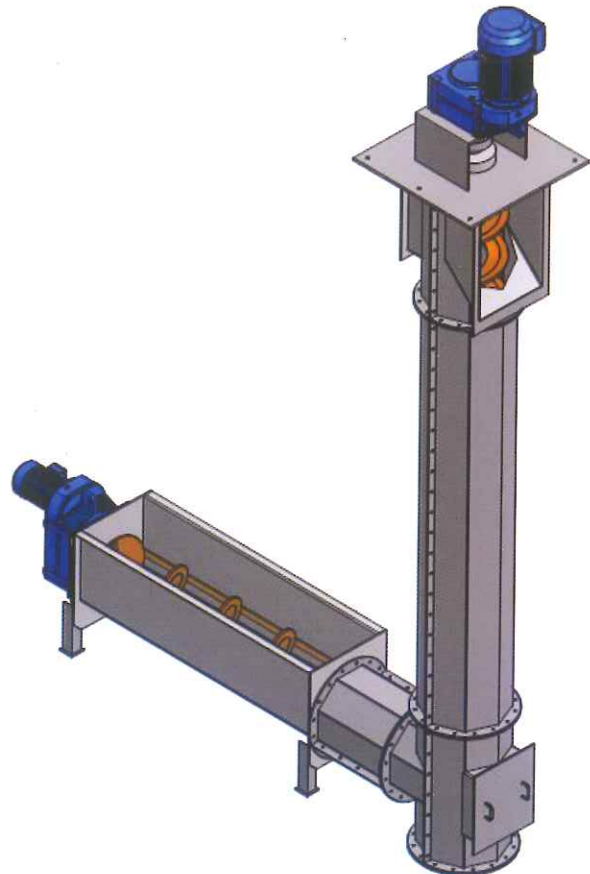



Sam McCoy Manufacturing Sdn Bhd
No.10, Jalan Sepintas 26/13,
40400 Shah Alam, Selangor, Malaysia.
Tel : +603 5191 7711
Fax : +603 5191 7722
www.sammccoy.com.my
DIN EN ISO 9001.MS ISO 14001



About Sam McCoy

Incorporated in 1988, Sam McCoy delivers innovative technology and products for the water and wastewater industry. In recent years, we have diversified into providing products and solutions for other industries such as palm oil, pulp and paper, food processing etc.

Since our establishment, we have helped our customers stay ahead of the demands for more advance and effective technology and solutions. Today, Sam McCoy remains uniquely positioned to maintain industry leadership based on our core competencies in engineering, design, fabrication and services. We are committed to having an exclusive focus on providing solutions that solve the toughest and most complex problems for our customers – delivering on the promise of ensuring total customer satisfaction.